

The Adjustable Voltage Regulator

Many amateurs have stopped by their local Radio Shack store and have noticed the famous LM317T adjustable voltage regulator. But, did you know that all voltage regulators are adjustable? Yes, any IC voltage regulator can be adjusted to a higher voltage than its fixed voltage by just adding a couple of resistors.

As an example, let's consider using the popular 7805 (5 volt) voltage regulator as a 12 volt regulator. In figure 1, let's assume 470 for R1 which means that a constant current of 10.6 mA will be seen between terminals 2 and 3. This constant current plus a regulator standby current of about 2.5mA will flow through R2 to ground regardless of its value. Because of this constant 13.1 mA, R2 can now be set to a value which will give us a constant 7 volts across this resistor. A resistor value of 533 ohms or 510 (standard value) will give us the necessary 7 volts. With 5 volts across R1 and 7 volts across R2, a total regulated value of about 12 volts will appear across terminal 2 and ground. If a variable resistor is used for R2, then the output voltage can be easily fine tuned to any value greater than 5 volts. The regulator standby current will vary slightly in the 7805 but 2.5mA will yield good results in the calculations. If an exact voltage (within .3 volts) is needed then R2 must be a variable resistor.

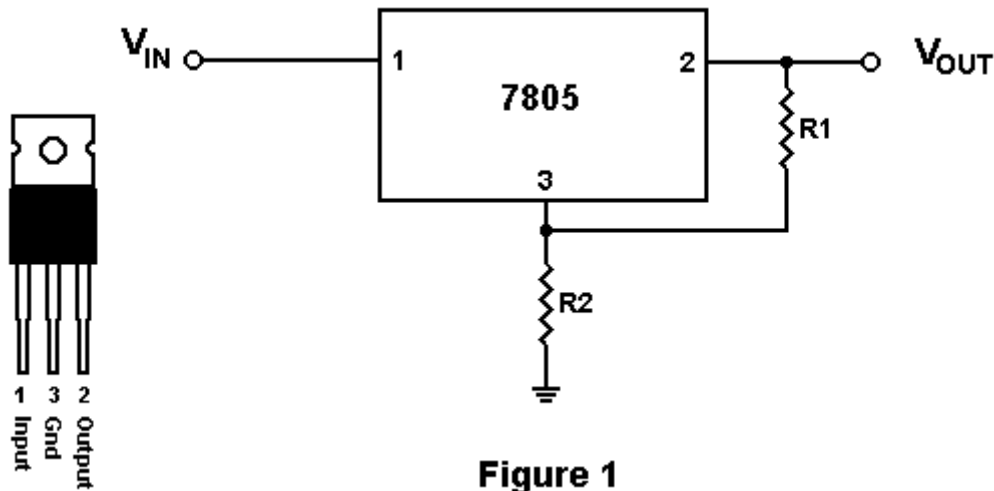

Figure 1

To make any fixed regulator adjustable, use the following formula:

$$V_{out} = V_{fixed} + R2(V_{fixed}/R1 + I_{stndby})$$

V_{out} = Desired output voltage

V_{fixed} = Fixed voltage of IC regulator (5 volts for 7805 or 1.25 volts for LM317T)

$R1$ = Assume any value from about 470 to 1K for best results

I_{stndby} = Standby current of regulator (use 2.5mA for 7805 or zero for LM317T)

Common Resistor Combinations for the 7805 regulator:

Vout (Approx.)	R1	R2
6 Volts	470	100
8 Volts	470	220
9 Volts	470	330
12 Volts	470	510

Incidentally, the famous LM317T adjustable regulator is really nothing more than a fixed regulator with an output voltage of 1.25 volts. Amateurs seldom need voltages below 5 volts so the 7805 regulator is a good choice and it even costs a little bit less than the LM317T.

DE N1HFX